

# Type CR Honing Units

## For Rod Reconditioning (Journal End)

Range: 1.450"-4.700" (36,8-119,4 mm)

These honing units will produce a round and straight rod bore and allow you to recondition the rod to original factory size, assuring a perfect fit of inserts.

### How to Order

Order LBN-62 Honing Unit Set for complete coverage of most popular cars and trucks. Covers diameters from 1.600" to 2.700" (36,8 to 68,6 mm). OR

Order individual honing units as needed. Each unit is complete with wedge, wedge plates and shoes.

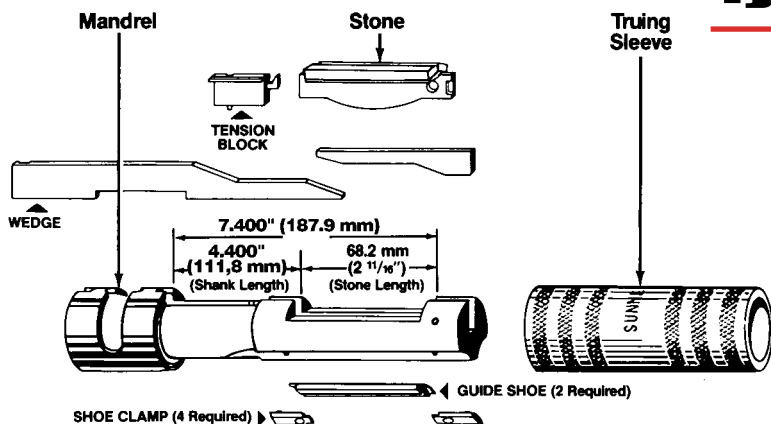

After cap and rod faces have been ground at right angles to the side of the rod to reduce the diameter of the bore, these honing units are used to bring the bore back to standard size.

They are specially designed to remove stock from the reduced bore without enlarging the diameter across the parting line.

For Complete Honing Unit Order		Honing Units				Replacement Parts			
		1 Mandrel		2 Stones		Shoe (2 per Pkg.)	Wedge Plate		Wedge
Range		Mandrel Part No.	Ship. Wt.		Ship Wt. 1/4 lb. (.11 kg)	Ship Wt. 1/4 lb. (.11 kg)	Ship Wt. 1/4 lb. (.11 kg)		
inches	mm		lbs.	kg.					
1.450-1.600	36,8-40,6	CR-1450	5-3/4	2,6	Select From Chart Below	CR-40D	CR-85	CR-75	CR-70
1.600-1.750	40,6-44,4	CR-1600*	5-3/4	2,6		CR-40D	CR-85	CR-75	CR-70
1.750-1.900	44,4-48,3	CR-1750*	5-3/4	2,6		CR-40D	CR-85	CR-75	CR-70
1.900-2.100	48,3-53,3	CR-1900*	6-1/2	2,9		CR-50D	CR-120	CR-110	CR-100
2.100-2.300	53,3-58,4	CR-2100*	8	3,6		CR-50D	CR-120	CR-110	CR-100
2.300-2.500	58,4-63,5	CR-2300*	9-1/2	4,3		CR-50D	CR-120	CR-110	CR-100
2.500-2.700	63,5-68,6	CR-2500*	11-1/4	5,1		CR-50D	CR-120	CR-110	CR-100
2.700-2.900	68,6-73,7	CR-2700	13	5,9		CR-50D	CR-120	CR-110	CR-200
2.900-3.100	73,7-78,7	CR-2900	14-1/2	6,6		CR-50D	CR-120	CR-110	CR-200
3.100-3.300	78,7-83,8	CR-3100	17	7,7		CR-50D	CR-120	CR-110	CR-200
3.300-3.500	83,8-88,9	CR-3300	6-1/2	2,9		CR-50D	CR-120	CR-110	CR-300A
3.500-3.700	88,9-94,0	CR-3500	7	3,2		CR-50D	CR-120	CR-110	CR-300A
3.700-3.900	94,0-99,1	CR-3700	7-1/2	3,4		CR-50D	CR-120	CR-110	CR-400A
3.900-4.100	99,1-104,1	CR-3900	8	3,6		CR-50D	CR-120	CR-110	CR-400A
4.100-4.300	104,1-109,2	CR-4100	8-1/2	3,9		CR-50D	CR-120	CR-110	CR-400A
4.300-4.500	109,2-114,3	CR-4300	8-1/2	3,9		CR-50D	CR-120	CR-110	CR-400A
4.500-4.700	114,3-119,4	CR-4500	9-1/2	4,3		CR-50D	CR-120	CR-110	CR-400A

\*Included in Set LBN-62.

### Replacement Parts

#### Tension Block

LN-1685A—For CR-1450 thru CR-1750.  
LN-1337A—For CR-1900 and up.

#### Shoe Clamps

(Includes 4 clamps and screws.)  
LN-1637A—For CR-1450 thru CR-1750.  
CR-45A—For CR-1900 and up.  
Includes CR-44A (pkg. 4 screws).

#### Bronze Shoes

For Power and Long Life (Manually Stroked Rod Reconditioning).

For CR-1450 thru CR-1750 Mandrels—order P/N PD-B.

For CR-1900 thru CR-4500 Mandrels—order P/N CR-50B.

### 2 Stone Selection Chart

CR Stones for CR-1450 Thru CR-1750 Mandrels	
CR-2	Medium Finishing
CR-4	Fine Finishing
Y44-J65	Aluminum Rods
CR Stones for CR-1900 Thru CR-4500 Mandrels	
CR-9	Aluminum Rods/Titanium
CR-10	For Rough Honing, Manual Stroking
CR-10N	For Rough Honing, Power Stroking
CR-12	For Medium Finish Honing, Manual Stroking
CR-12-8	For Medium Finish Honing, Power Stroking
CR-14	For Fine Finish Honing, Manual Stroking

# All-Steel and Lifetime Honing Units

## For Connecting Rods (Pin Fitting)

Range: .744"-2.625" (18,9-66,7 mm)

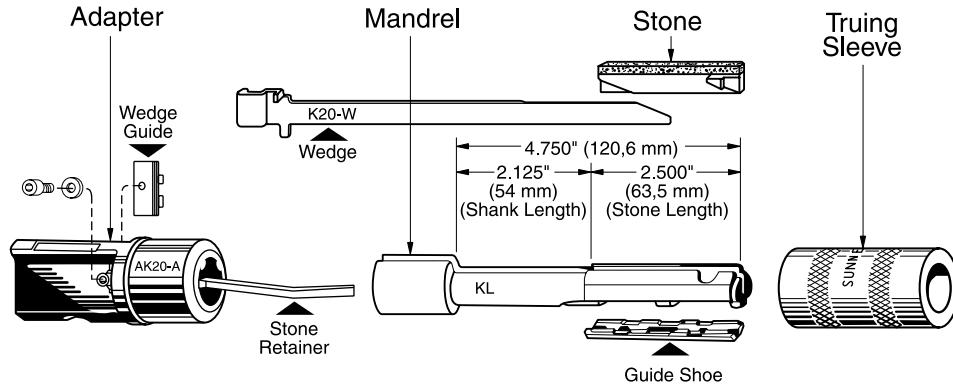

### For Con-Rod Bushings and Press-Fit Type Rods

All-steel and Lifetime mandrels, specially made for fitting pins in con-rods. Stone and shoe are of proper length to produce straight, round, accurate holes. The all-steel mandrels do not have replaceable shoes. Order in Convenient Sets.

Part No.	Stones
KL-5	Roughing Stone for fast removal of stock in bronze bushings.
KL-7	Medium finishing stone for bronze and aluminum.
KL-13	Finishing stone for bronze and aluminum.
KL-14	Stones for honing press-fit type rods.

Part No.	Replacement Parts
K20-W	Replacement Wedge (Should be replaced when it begins to show wear.)
LN-3688A	Replacement Stone Retainer
LN-3218A	Replacement Wedge Guide

**Notes:** 1. Length of Honing Stone Surface—2-1/2" (63,5 mm).  
2. Allow for extra stock in new bushings to be sure mandrel will enter the hole.

For Complete Honing Unit Order		Honing Units									Replacement Guide Shoe (Included with Mandrels) 2 per Pkg.
1	2	3	4	1 Mandrel (Includes K-20-W Wedge and Shoes)		2 Truing Sleeve	3 Adapter (Includes Retainer)	4 Stones (12 per Pkg.)			
Range		Mandrel Part No.	Ship. Wt.		Ship. Wt.	Ship. Wt.	Rough	Finish	Steel Applications	Ship Wt. per Pkg. 1/4 lb. (.11 kg)	
inches	mm		lbs.	kg.	1 lb. (.45 kg)	3/4 lb. (.34 kg)					
<b>All-Steel Honing Units</b>											
.619- .650	15,7-16,5	KL-619M	1/2	,23	S-619	K20-A	KL-5	KL-13	KL-14	None	
.650- .680	16,5-17,3	KL-650 M	1/2	,23	S-650	K20-A	KL-5	KL-13	KL-14	None	
.681- .712	17,3-18,1	KL-681 M	1/2	,23	S-681	K20-A	KL-5	KL-13	KL-14	None	
.713- .743	18,1-18,9	KL-713 M	1/2	,23	S-713	K20-A	KL-5	KL-13	KL-14	None	
<b>Lifetime Honing Units</b>											
.744- .774	18,9-19,7	KL-744M†	1/2	,23	S-744†	AK-20A†	KL-5	KL-13	KL-14	UA-B	
.775- .805	19,7-20,4	KL-755 M	3/4	,34	S-775	AK-20A	KL-5	KL-13	KL-14	UA-B	
.806- .837	20,5-21,3	KL-806 M	3/4	,34	S-806	AK-20A	KL-5	KL-13	KL-14	UB-B	
.838- .868	21,3-22,0	KL-838 M†	3/4	,34	S-838†	AK-20A†	KL-5	KL-13	KL-14	UB-B	
.869- .899	22,1-22,8	KL-869 M	3/4	,34	S-869	AK-20A	KL-5	KL-13	KL-14	UB-B	
.900- .930	22,9-23,6	KL-900 M†	1	,45	S-900†	AK-20A†	KL-5	KL-13	KL-14	UC-B	
.931- .961	23,6-24,4	KL-931 M†	1	,45	S-931†	AK-20A†	KL-5	KL-13	KL-14	UC-B	
.962- .993	24,4-25,2	KL-962 M†	1	,45	S-962†	AK-20A†	KL-5	KL-13	KL-14	UC-B	
.994-1.062	25,2-27,0	KL-1000 M†	1	,45	S-994†	AK-20A†	KL-5	KL-13	KL-14	UD-B	
1.056-1.125	26,8-28,6	KL-1062 M†	1-1/4	,6	S-1062†	AK-20A†	KL-5	KL-13	KL-14	UD-B	
1.119-1.187	28,4-30,1	KL-1125 M†	1-1/4	,6	S-1125†	AK-20A†	KL-5	KL-13	KL-14	UE-B	
1.181-1.250	30,0-31,7	KL-1187 M†	1/4	,6	S-1187†	AK-20A†	KL-5	KL-13	KL-14	UE-B	

† Included in LBN-64 Set.

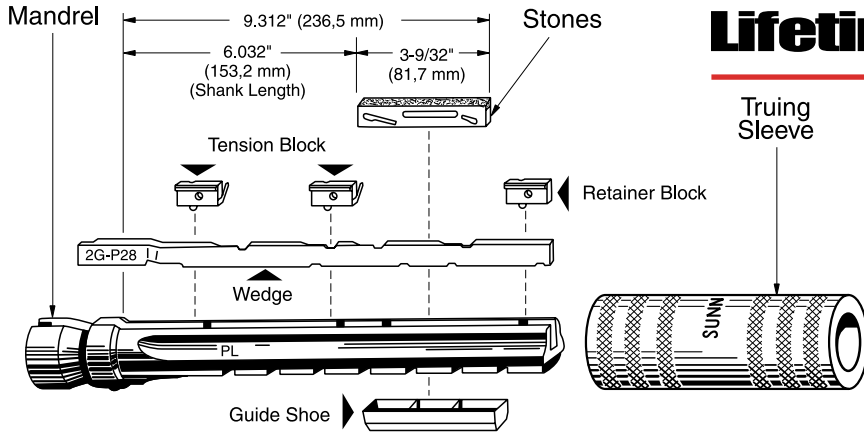

# Lifetime Honing Units

**For Connecting Rods (Pin Fitting)**

**Range: .990"-2.625" (25,1-66,7 mm)**

**For:**

- Pin fitting in con-rods over 1.000" (25,4 mm)
- Small cylinders in motorcycles, lawn mowers, outboard motors, etc.

Mandrel does not wear...shoes are replaceable.

**Notes:**

1. Length of Honing Stone Surface—3-9/32" (81,7 mm).
2. Allow for extra stock in new bushings to be sure honing unit will enter the hole.

For Complete Honing Unit Order <b>1 2 3</b>		Honing Units										Replacement Parts (Included with Mandrel)		
		<b>1</b> Mandrel (Includes Wedge and Shoes)		<b>2</b> Truing Sleeve				<b>3</b> Stones PL-Type (12 per Pkg.)						
Range		Mandrel Part No.	Ship. Wt.		Part No.	Ship. Wt.		Rough	Med. Finish	Fine Finish	Steel Applications	Shoe (2 per Pkg.)	Shim Sets	Wedge
inches	mm		lbs.	kg.		lbs.	kg.							
.990-1.062	25,1-27,0	1PL-1000M*	2-1/2	1,1	ST-1000	1-1/2	,68	PL-5	PL-7	PL-13	PL-14	VA-B	LN-1144	2G-P28
1.052-1.125	26,7-28,6	1PL-1062M*	2-3/4	1,25	ST-1062	1-3/4	,79	PL-5	PL-7	PL-13	PL-14	VA-B	LN-1144	2G-P28
1.115-1.187	28,3-30,1	1PL-1125M*	3	1,36	ST-1125	1-3/4	,79	PL-5	PL-7	PL-13	PL-14	VB-B	LN-1144	2G-P28
1.177-1.250	29,9-31,7	1PL-1187M*	3-1/4	1,47	ST-1187	2	,91	PL-5	PL-7	PL-13	PL-14	VB-B	LN-1144	2G-P28
1.230-1.375	31,2-34,9	1PL-1250M*	3-1/4	1,47	ST-1250	2	,91	PL-5	PL-7	PL-13	PL-14	WB-D	LN-1144	2G-P28
1.355-1.500	34,4-38,1	1PL-1375M*	3-1/4	1,47	ST-1375	2-1/4	1,02	PL-5	PL-7	PL-13	PL-14	WC-D	LN-1144	2G-P28
1.480-1.625	37,6-41,3	1PL-1500M*	3-3/4	1,70	ST-1500	2-1/4	1,02	PL-5	PL-7	PL-13	PL-14	WD-D	LN-1148	2G-P28
1.605-1.750	40,8-44,4	1PL-1625M*	4-1/2	2,04	ST-1600	2-1/4	1,02	PL-5	PL-7	PL-13	PL-14	WD-D	LN-1148	2G-P28
1.730-1.875	43,9-47,6	1PL-1750M	5-1/2	2,50	ST-1700	2-3/4	1,25	PL-5	PL-7	PL-13	PL-14	WE-D	LN-1148	2G-P28
1.855-2.000	47,1-50,8	1PL-1875M	6-1/2	2,95	ST-1875	3-3/4	1,70	PL-5	PL-7	PL-13	PL-14	WE-D	LN-1148	2H-P28
1.980-2.125	50,3-54,0	1PL-2000M	7-1/4	3,29	ST-2000	3-3/4	1,70	PL-5	PL-7	PL-13	PL-14	WF-D	LN-1148	2H-P28
2.105-2.250	53,5-57,1	1PL-2125M	8-1/4	3,75	ST-2100	3-3/4	1,70	PL-5	PL-7	PL-13	PL-14	WF-D	LN-1148	2H-P28
2.230-2.375	56,6-60,3	1PL-2250M	9-1/2	4,31	ST-2200	4	1,81	PL-5	PL-7	PL-13	PL-14	WF-D	LN-1148	2H-P28
2.355-2.500	59,8-63,5	1PL-2375M	10-1/4	4,65	ST-2375	6-1/4	2,84	PL-5	PL-7	PL-13	PL-14	WG-D	LN-1148	2H-P28
2.480-2.625	63,0-66,7	1PL-2500M	11-3/4	5,34	ST-2500	6-1/4	2,84	PL-5	PL-7	PL-13	PL-14	WG-D	LN-1148	2H-P28

\*Requires eccentric sleeve LN-0116A.

## PHT Plateau Honing Tool

For Use With PL Mandrels

Tool	For Diameter Range	Abrasive Sets (320 GRIT)
PL Style Mandrels	.990-6.00" (25,146-152,4 mm)	P28-PHT-731 (fits all PL style mandrels)

## B-300 Countersink

For chamfering the wrist pin end of connecting rods. The B-300 Countersink includes an adapter for chucking into the Sunnen Honing Machine and will chamfer bushed type as well as press-fit connecting rods. Chamfering the rod eyes makes assembling the wrist pin easier and eliminates the possibility of galling during installation. The unit is sold complete and ready for use in any Sunnen Honing Machine. Range: 3/8" through 1-3/8" (9,5-34,9 mm) diameters.

Shipping Weight: 1-1/2 lbs. (.68 kg)

## For Blind Hole Work...

The honing units listed above can be converted by ordering: **A** and **B**

<b>A</b> Wedge		<b>B</b> Stone			
Mandrel	Order Wedge No.	For Honing	Rough	Finish	Polish
1PL-1000M to 1PL-1750M	2G R28	Steel	RL-8	RL-14	RL-17
1PL-1875M to 1PL-2500M	2H-R28	Cast iron, Bronze, Aluminum	RL-7	RL-13	RL-17

Note: Special short length hard tip stones and shoes available for honing short wheel cylinders. Call customer service department.

## Sunnen CRG-960 Rod Clamping Fixture

May be mounted on Sunnen Storage Cabinet Bench (CRG-600) or Workbench, or it may be clamped in a standard Machinist's Vise. Note: CRG-960 is included with CRG-780 Cap and Rod Grinder. Shipping Weight: 14 lbs. (6,36 kg)

## LBN-730 Rod Support

Enables the operator to hone two V-6 or V-8 rods at the same time. Eases production problems associated with honing narrow connecting rods. Shipping Weight: 6 lbs. (2,7 kg)